

TOP VIEW : CUT-AWAY

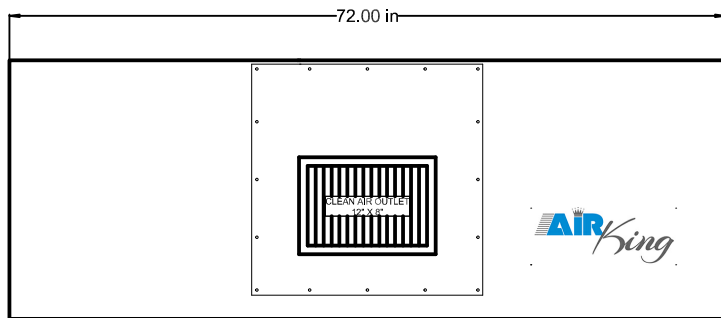

FRONT VIEW

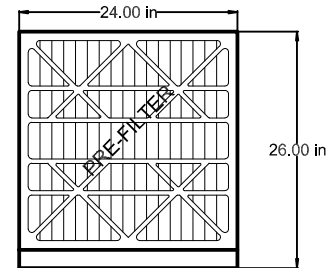
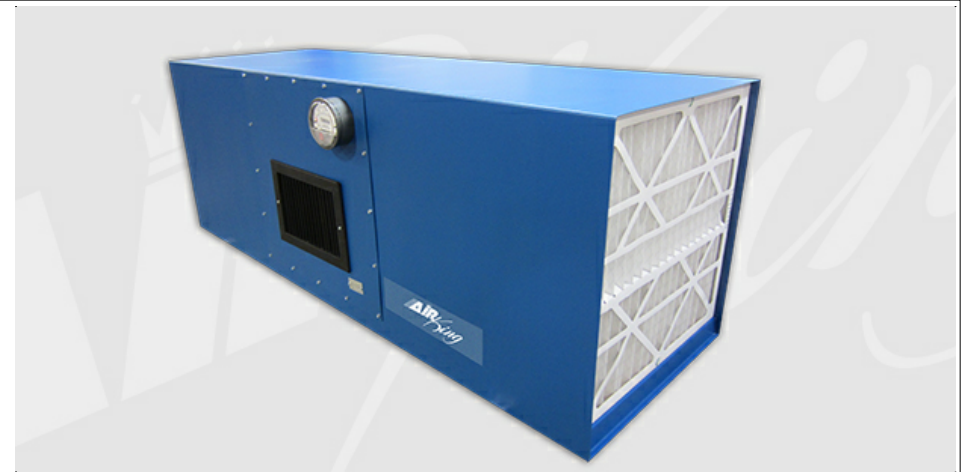

SIDE VIEW

**SPECIFICATIONS:**

DIMENSIONS: 24"W x 26"T x 72"L  
 WEIGHT: 300 LBS.  
 VOLUME: 3500 CFM  
 PRE-FILTER: (2) 24"x24"x4" Pleated (Merv 8)  
 PRIMARY BAG FILTER: (2) 95%, 15" 12 pocket Bags (120 sq ft)  
 MOTOR: 2HP TEFC; 208-230/460/3/60; 6.0-5.8/2.9 amps  
 BLOWER: 11" x 8" Belt Drive, Single Speed  
 CONSTRUCTION/PAINT : 16 GA, River Blue chemical resistant powder coating  
 NOISE LEVEL 5' dBA : 72 dBA  
 APPLICATION: Lite Odor Control

**M-30CCF (CHARCOAL PANEL FILTER)**



Iowa Distributing Co., Inc.  
 5200 Nordic Drive Suite B  
 Cedar Falls, IA 50613  
 P: 319.266.5411  
 F: 319.277.3304  
[www.AirKingFiltration.com](http://www.AirKingFiltration.com)